

CAD FILE:

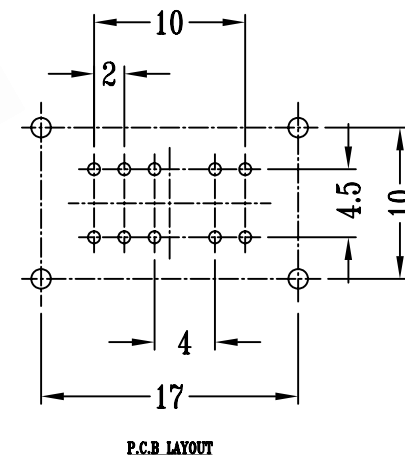
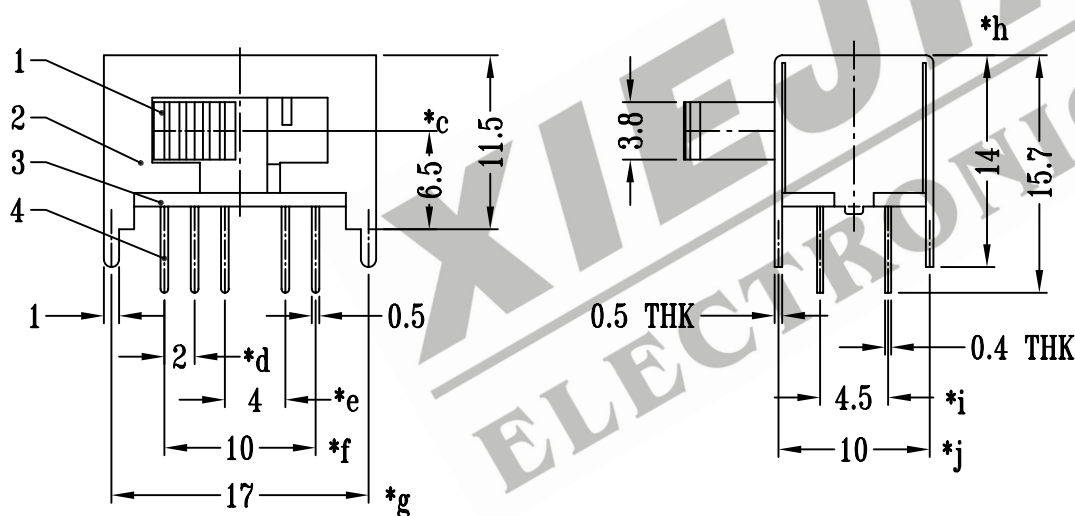
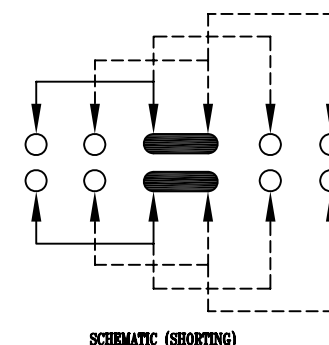
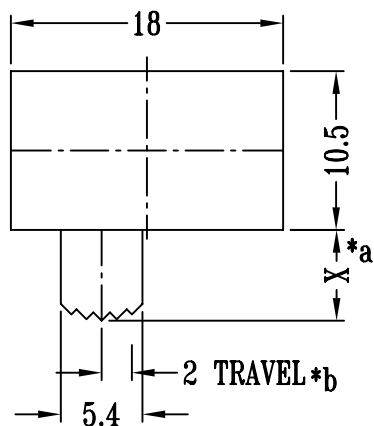

注:带\*表示关键尺寸(10个)

NO.	PARTS	MATERIALS	Q'TY	FINISH	TOLERANCE UNLESS SPECIFIED	SHENZHEN XIEJIA ELECTRONICS CO.,LTD.							
8						ISSUE	DATE	DESCRIPTIONS OF REVISION		APPD.			
7	STEEL BALL	STEEL	1	NATURAL									
6	SPRING	STEEL WIRE	1	TEMPER	WITHIN: 1.5 ±0.1mm OVER: 1.5 ±0.2mm								
5	CONTACT CLIP	PBS STRIP	2	Ag PLATED									
4	TERMINAL	BRASS STRIP	10	Ag PLATED OVER Ni PLATED	TITLE : HORIZONTAL SLIDE SWITCH	UNIT : mm	DRWG NO.: XJ-DR-SK24D01-00						
3	BASE	PHENOLIC RESIN	1	NATURAL	MODEL: SK-24D01	SCALE: 2:1	DWN.	ZHOUYU	2001-3-26				
2	FRAME	STEEL STRIP	1	Ni PLATED			CHK'D	FANGYING	2001-3-26				
1	KNOB	POM	1	BLACK	ALL MATERIALS MUST BE COMPLIANT TO ROHS		APPD.	KANGXINAN	2001-3-26				